



ESW-5112-2MG Series

**L2 Managed Switch with
8-Port 10/100/1000M RJ-45
2-Port 100M/1G/2.5G/5G/10G RJ-45
and 2-Port 1/10G SFP+**

User's Guide

Version: 1.0

Revision History

Version	Date	Changes
1.0	08/25/2023	First release

FCC Warning

This equipment has been tested and found to comply with the limits for a Class A digital device, pursuant to Part 15 of the FCC Rules. These limits are designed to provide reasonable protection against harmful interference when the equipment is operated in a commercial environment. This equipment generates, uses, and can radiate radio frequency energy and, if not installed and used in accordance with this user's guide, may cause harmful interference to radio communications. Operation of this equipment in a residential area is likely to cause harmful interference in which case the user will be required to correct the interference at their own expense.

CE Mark Warning

This is a Class A product. In a domestic environment, this product may cause radio interference in which case the user may be required to take adequate measures.

Trademarks

CTS is a registered trademark of Connection Technology Systems Inc. All trademarks belong to their respective proprietors.

Contents subject to change without prior notice.

Copyright Statement

Connection Technology Systems Inc. Copyright © 1998-2023

This publication may not be reproduced as a whole or in part, in any way whatsoever unless prior consent has been obtained from Connection Technology Systems Inc.

CTS Contact Information

■ Headquarters/Manufacturer:

Connection Technology Systems Inc.

18F-6, No.79, Sec.1, Xintai 5th Rd.,

Xizhi Dist., New Taipei City 221,

Taiwan(R.O.C.)

Tel: +886-2-2698-9661

Fax: +886-2-2698-3960

Sales Direct Line: +886-2-2698-9201

www.ctsystem.com

■ Global Offices:

Connection Technology USA

40538 La Purissima Way,

Fremont, CA 94539, USA

Tel: +1-510-509-0304

Sales Direct Line: +1-510-509-0305

E-mail: cts_us@ctsystem.com

Connection Technology Systems NE AB

E A Rosengrens gata 31,

421 31 Västra Frölunda,

Sweden

Tel: +46 31 22 19 80

E-mail: info@ctsystem.se

Connection Technology Systems India Private Limited

No.1, 1st Floor, RK Residency Vajarahalli,

Uttarahalli, Talgatpura, Kanakpura MN

Rd, Bangalore, Karnataka, India, 560062

E-mail: kirti_simha@ctsystem.com

Connection Technology Systems Japan

Higobashi Bldg. No.3 R201, 1-23-13,

Edobori, Nishi-ku, Osaka 550-0002, Japan

Tel: +81-6-6450-8890

E-mail: cts_japan@ctsystem.com

Connection Technology Systems Central Europe (COMPONET Handels GmbH)

Hirschstettner Straße 19-21/Stiege I

A-1220 Vienna, Austria

Tel: +43-1-235 05 66-0

E-mail: cts_ce@ctsystem.com

Table of Contents

Revision History.....	ii
CTS Contact Information	iii
1. Introduction.....	2
1.1 Overview of ESW-5112-2MG.....	2
1.2 Key Features.....	3
1.3 Front & Rear Panels	6
1.3.1 Front Panel.....	6
1.3.2 Rear Panel	8
1.4 LED Definitions	9
1.5 Cable Specifications.....	11
2. Installation.....	12
2.1 Installation Requirements.....	13
2.2 Checking the Package Contents.....	13
2.3 Installing the Managed Switch	14
2.3.1 Desktop Installation	14
2.3.2 Rack Installation	15
2.3.2.1 Install a Managed Switch in a Rack	15
2.3.2.2 Install Two Managed Switches in a Rack Using the Combine Kit	17
2.3.2.3 Install a Single/Two Managed Switches in a Rack Using 19-inch Rack-mount Bracket.....	20
2.4 Grounding the Managed Switch.....	22
2.5 Powering on the Managed Switch.....	23
2.6 Connecting the Managed Switch to the Network	23
2.7 Installing and Removing SFP/SFP+ Modules	23
2.7.1 Installing SFP/SFP+ Modules.....	23
2.7.2 Removing SFP/SFP+ Modules.....	24
2.8 Connecting the Switch to Console Port.....	24
3. Operation.....	25
3.1 Network Management.....	25
4. Maintenance.....	27
4.1 Fault Identification.....	27

4.1.1 Local Check.....	27
4.1.2 Remote Check.....	28
4.2 Hardware Replacement Procedures	28
4.3 Firmware Upgrade	28

About this manual

In this user's guide, it will not only clearly introduce CTS ESW-5112-2MG Managed Switch but tell you how to install this Managed Switch with detailed instructions.

Organization of the Manual

- Chapter 1 "Introduction" describes the features of the Managed Switch
- Chapter 2 "Installing the Managed Switch"
- Chapter 3 "Operation"
- Chapter 4 "Maintenance"

1

Introduction

CTS's Managed Switch is designed to meet the emerging FTTX & Metro Ethernet requirements. Besides the low profile appearance with 1U height and the standard 8.5-inch rack-mounted size, the product also achieves hassle-free monitoring and comprehensive management for any network operator who desires to build up a reliable telecommunication network infrastructure. When it comes to FTTX deployment, the Managed Switch provides the best performance and price ratio.

1.1 Overview of ESW-5112-2MG

The product is a 8.5-inch and rack mountable Managed Switch, equipped with 8 Gigabit Ethernet ports (10/100/1000Base-T), 2 Multi-G Ethernet ports (100M/1G/2.5G/5G/10GBase-T), and 2 SFP+ ports (1/10GBase-R) on the front panel. This Managed Switch provides high performance, store and forward switching capability plus other advanced features such as QoS, VLAN, Spanning Tree, LACP and so on.

LED indicators located on the front panel ease the users' effort to monitor and manage the network status. The built-in management module also allows users to configure, control and monitor the system locally via console or remotely via SNMP-based management system.

This Managed Switch is a typical SFP/SFP+ solution to FTTX service implementation. Besides, it can be used as a stand-alone switch. With the height of 1U and the 8.5-inch standard-size rack design in appearance, the network switch can be used in closet wiring as well.

1.2 Key Features

■ Interface

- RJ-45 Port
 - 8 x 10/100/1000Base-T RJ-45
 - 2 x 100M/1G/2.5G/5G/10GBase-T RJ-45
- Fiber Port
 - 2 x 10GBase-SR/LR SFP+
 - Compatible with 1000Base-X Transceiver
- Console Port
 - 1 x RS-232 to RJ-45 Serial Port
- Terminal Block
 - 1 x Digital Input (Dry Contact)

■ H/W Specification

- MAC Address Table: 16K
- Non-Blocking Switching Fabric: 96Gbps
- Throughput @ 64Bytes: 71.4Mpps
- Packet Buffer: 12Mbit
- Jumbo Frame: 12K Bytes
- Store and Forward Switching Mechanism
- Auto-Cross Over for MDI/MDIX in TP Ports
- Auto-Negotiation in TP Ports
- Full/Half Duplex Mode Operation

■ Layer 2 Switch Features

VLAN

- IEEE 802.1q VLAN
 - VLAN ID: 4094 IDs
 - VLAN Concurrent Groups: 4K VLAN Groups
- Port-Based VLAN
- VLAN Translation
- Q-in-Q Double Tag with Configurable EtherType
- Selective Q-in-Q

QoS

- QoS 802.1p CoS / DSCP
- Scheduling Algorithm
 - Weighted Round Robin (WRR)
 - Strict Priority Queuing (SPQ)
- QoS Priority Queues: 8 Queues
- 802.1p P-bit & DSCP Remarking
- Port-Based Rate Limit (Ingress/Egress)

Network Redundancy

- IEEE 802.1d Spanning Tree Protocol (STP)
- IEEE 802.1w Rapid Spanning Tree Protocol (RSTP)
- Fast Redundancy (Fast Ring v2 / Chain Protocols)
- IEEE 802.3ad Link Aggregation (LACP)

- Static Port Trunking
- Up to 6 Aggregation Groups, 8 Ports per Group

Multicast

- IGMP Snooping v1/v2/v3
- IGMP Fast Leave and Querier
- MLD v1/v2 Snooping
- MLD Querier
- IGMP/MLD Snooping Group: 512/128 Groups
- IP Multicast Filter with Segment and Profile
- Static Multicast Group
- Multicast VLAN Replication (MVR)

IPv6 Feature

- IPv6 over Ethernet (RFC 2464)
- IPv6 Addressing Architecture (RFC 4291)
- IPv6 Dual Stack (RFC 4213)
- ICMPv6 (RFC 4884)
- Path MTU Discovery for IPv6 (RFC 1981)
- Neighbor Discovery (RFC 4861)
- DHCPv6 Client

Layer 2 Protocol Tunneling

- CDP, LLDP, STP, VTP, LACP, PAgP & UDLD

Access Control List

- Physical Port, Ether Type, MAC Address, VID, ToS/DSCP, Protocol Type, L4 Port and IP Address
- ACL Entries (IPv4: 64 Entries; IPv6: 32 Entries)

Security

- 802.1x Port Base Access Control
- 802.1x RADIUS Authentication
- 802.1x MAC Authentication Bypass
- RADIUS Based VLAN Assignment
- DHCP Option 82 Relay Agent
- DHCP Option 82 with Configurable Circuit and Remote ID
- DHCP Snooping and DHCP Server Trust Port
- IP Source Guard
- Port Isolation
- Storm Control
Unknown Unicast / Unknown Multicast / Broadcast
- MAC Limiter
- Loop Detection

Management

- SNMP v1, v2c & v3 / Web / Telnet / HTTPS / SSHv2 / CLI
- Text-Based CLI Configure File
- Port Configuration
Speed / Duplex / Flow Control / Description
- NTP with Daylight Saving Time
- Layer 2 Control Protocol Filter

Introduction

- Static MAC Address Table
- LLDP

Maintenance

Diagnostic

- Port Mirror
- ICMP Ping
- Event log
- Syslog
- SFP SFF-8472 DDMI & Threshold Monitor: Temp / Volt / TX Bias / TX Power / RX Power
- CPU
Temperature/Utilization
- Memory Statistics
- System Voltage
- Cable Diagnostics

Upgrade/Restore

- Firmware Upgrade/Downgrade
HTTP/HTTPS/FTP/TFTP
DHCP Auto-provision via DHCP Option 60/43
- Configuration Upload/Backup
HTTP/HTTPS/FTP/TFTP
DHCP Auto-provision via DHCP Option 60/43

■ **Power Requirement**

- Input AC: 100V ~ 240V, 50/60Hz, 0.4 ~ 0.2A
- Input DC: 48V, 0.4A
12V, 3.33A (External Power Supply, R7B Adapter)
- Power Adapter: 100 ~ 240VAC, 48VDC
- Power Consumption: 26.4W (90BTU/h)

■ **Environmental Condition**

- Operation: 0°C ~ 50°C
- Storage: -20°C ~ 60°C
- Humidity: 5% ~ 90%, Non-Condensing

■ **Dimension & Weight**

- Size: 210 x 235 x 44mm (W x D x H)
- Weight: 1.8kg

■ **EMC/Safety**

- FCC Class A, CE

1.3 Front & Rear Panels

1.3.1 Front Panel

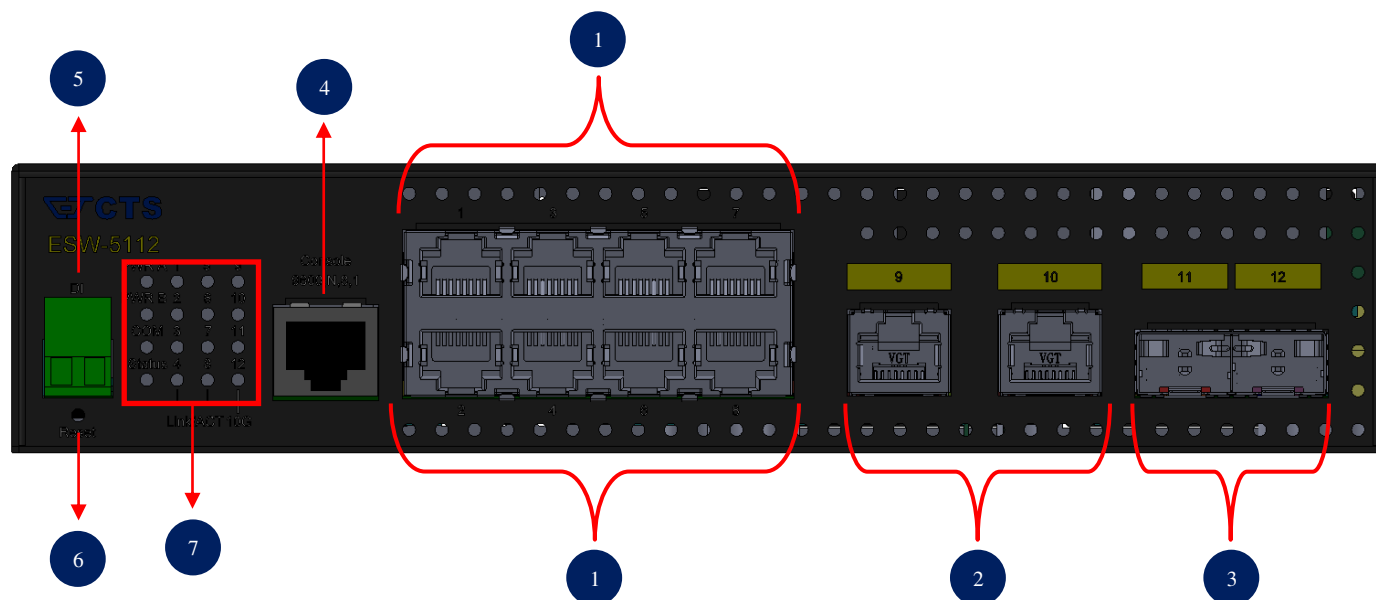

Figure 1-1. The Managed Switch Front Panel

The interfaces on the front panel of the Managed Switch are described below:

1. **8 x 10/100/1000Base-T RJ-45 Ports (Port 1-8)**
2. **2 x 100M/1G/2.5G/5G/10GBase-T RJ-45 Ports (Port 9-10)**
3. **2 x 1/10GBase-R SFP+ (Port 11-12)**
4. **Console Port:**
 - An asynchronous serial console port supports the RS-232 electrical specification. The console port can be used to manage the device, and the serial console port settings should be configured as 9600, 8, n, 1.
5. **Digital Input (Dry Contact):**
 - A voltage-free connector that is used to decide whether the trigger occurs or not by detecting its open/close status. The configuration is as follows:
 - Open: Logic Level 0
 - Close: Logic Level 1
6. **Reset Button:**
 - Press the reset button for 5-10 seconds, then release it to restart the system.
 - Press the reset button for more than 10 seconds, then release it to reset the Managed Switch. The settings will be back to the factory defaults and restart the system.

7. LEDs:

- Includes Power LEDs, COM LED, Status LED, LEDs of TP 1-10 ports and LEDs of SFP+ 11-12 ports. For more details on LEDs description, please refer to Section [1.4 LED Definitions](#).

1.3.2 Rear Panel

The Managed Switch provides one fixed power module or two fixed power modules for redundancy purpose. Depending on your physical environment requirements, the type of power module is selectable and could be AC input, DC input, or external power DC input.

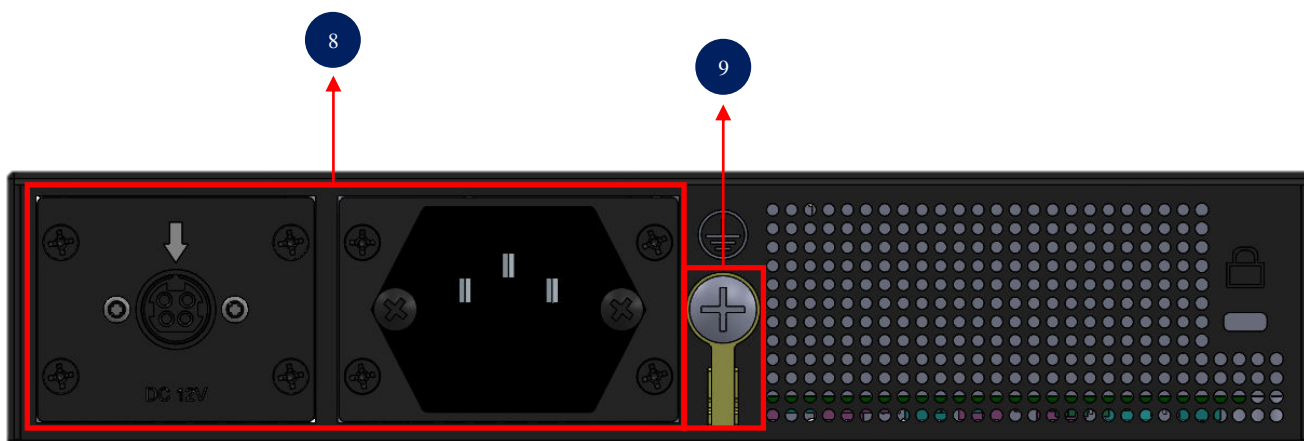

Figure 1-2. The Managed Switch Rear Panel

The interface on the rear panel of the Managed Switch is described below:

8. Power module and connector:

- AC power connection: 100V ~ 240V, 50/60Hz, 0.4 ~ 0.2A
- DC power connection: 48V, 0.4A
12V, 3.33A (External power supply, R7B adapter)

To ensure the normal operation of the device, please follow these specifications when purchasing R7B power adapter:

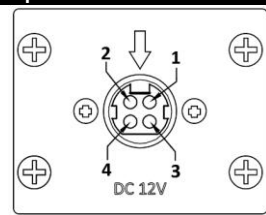

- a.) Supports R7B male output connector
- b.) Supports 12V DC +/- 10% with minimum 3.33A output
- c.) Output pin 1 & 2 should assigned as positive; Output pin 3 & 4 should assigned as negative.
- d.) The DC output cable need to be at least 18AWG



CAUTION/ATTENTION

Shock hazard. Ensure all power sources have been disconnected before unit servicing.

Failure to comply with the procedure might induce personal injuries and component damages due to the electrical power present within the enclosure.

9. Ground Screw (For more information, please refer to [Section 2.4](#))

1.4 LED Definitions

The Managed Switch is Plug & Play compliant. The real-time operational status can be monitored through a set of LED indicators located on the front panel.

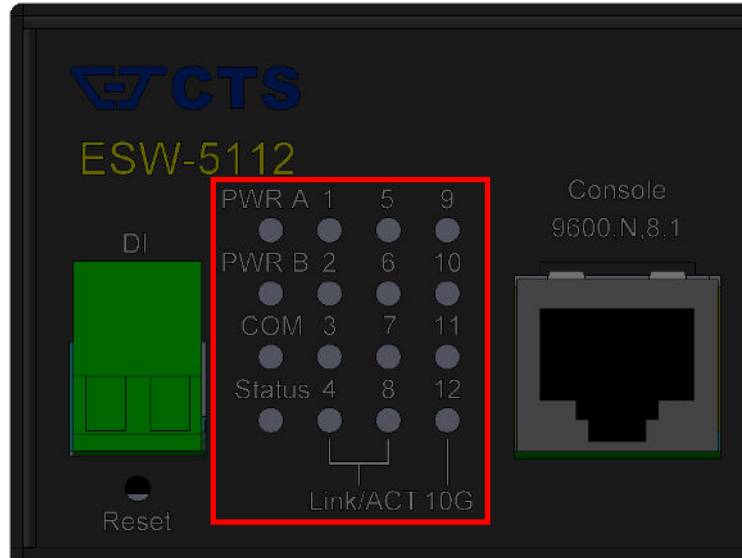

Figure 1-3. LEDs of the Managed Switch

Power A/B LED

The power status of the Managed Switch is indicated by the Power A/B LED on the front panel of the device.

LED	Color	Operation
Power A/B	OFF	No fixed-in power module exists or power is off.
	Green	Lit when power module is in normal operation.
	Orange	Fixed-in power module is no longer receiving power or DC output fails.

Status LED

The Managed Switch status is indicated by the Status LED on the front panel of the device.

LED	Color	Operation
Status	Green	Lit when the device is in normal operation.
	Orange	Lit when the device is booting up or press the Reset button for 5~10 seconds and then release to restart the system.
		Blinking when pressing the Reset button for more than 10 seconds and then release to reset (return to factory default settings) and restart the system. The LED indicator will blink in orange color for three times.

COM LED

The console status is indicated by the COM LED on the front panel of the device.

LED	Color	Operation
COM	OFF	Either the console port is not activated or no session exists.
	Green	Lit when the console port is activated and the session exists.

TP 1~8 Port LEDs

LED	Color	Operation
Link/ACT/ Speed	OFF	No connection exists.
	Green	Lit when the 10/100Mbps port link is up. Blinking when the port is receiving and transmitting data at the speed of 10/100Mbps.
	Orange	Lit when the 1000Mbps port link is up. Blinking when the TP port is receiving and transmitting data at the speed of 1000Mbps.

TP 9~10 Port LEDs

LED	Color	Operation
Link/ACT/ Speed	OFF	No connection.
	Orange	Lit when the 100Mbps/1Gbps port link is up. Blinking when the port is receiving and transmitting data at the speed of 100Mbps/1Gbps.
	Blue	Lit when the 2.5/5/10Gbps port link is up. Blinking when the port is receiving and transmitting data at the speed of 2.5/5/10Gbps.

SFP+ 11-12 Port LEDs

LED	Color	Operation
Link/ACT/ Speed	OFF	No connection.
	Orange	Lit when the 1Gbps port link is up. Blinking when the port is receiving and transmitting data at the speed of 1Gbps.
	Blue	Lit when the 10Gbps port link is up. Blinking when the port is receiving and transmitting data at the speed of 10Gbps.

1.5 Cable Specifications

The following table contains various cable specifications for the Managed Switch. Please make sure that you use the proper cable when connecting the Managed Switch.

Cable Type	Description
100BASE-FX	Multi-mode fiber module(2km) / Single-mode fiber module
1000BASE-SX	Multi-mode fiber module (550m)
1000BASE-LX	Single-mode fiber module (10km)
1000BASE-LH	Single-mode fiber module (30km/50km)
1000BASE-ZX	Single-mode fiber module (80km)
SFP Transceiver	SFP Transceiver for 1000BASE-SX Multi-mode fiber module (550m) SFP Transceiver for 1000BASE-LX Single-mode fiber module (10km) SFP Transceiver for 1000BASE-LH Single-mode fiber module (30km/50km) SFP Transceiver for 1000BASE-ZX Single-mode fiber module (80km)
10GBASE-SR	Multi-mode fiber module (26m or 400m)
10GBASE-LR	Single-mode fiber module (10km)
10GBASE-ER	Single-mode fiber module (40km)
10GBASE-LRM	Multi-mode fiber module (220m)

2

Installation

To properly install the Managed Switch, please follow the procedures listed below. These procedures will be respectively described in detail in the following sections.

- Installation Requirements
- Checking the Package Contents
- Installing the Managed Switch
- Grounding the Managed Switch
- Powering on the Managed Switch
- Connecting the Managed Switch to the Network
- Installing and Removing SFP/SFP+ Modules
- Connecting the Switch to Console Port

2.1 Installation Requirements

Basic requirements for installation are as follows:

- Environmental conditions
 - One power outlet
 - Proper ventilation
 - Proper isolation to electrical noise, radio, etc.
- Required SFP/SFP+ Transceiver
- Rack mounting tools

2.2 Checking the Package Contents

Unpack the package carefully and check the package contents. The package should contain the following items:

- One set of the Managed Switch
- 19-inch rack-mounting kit:
 - 1 x Long mounting bracket and 2 x regular mounting brackets
 - Screws
- Four rubber feet with adhesive backing
- Console RS-232 cable with RJ-45 connector
- Documentation CD
- AC power cord (Each AC power or external DC power input comes with one AC power cord)
- External power supply, R7B adapter (For models with external DC power input only)
- Two-switch combine kit for 19-inch rack-mounting. (Optional)
 - 4 x L-shaped fixed pieces
 - Screws

If any item is found missing or damaged, please contact your local sales representative for support or replacement.

2.3 Installing the Managed Switch

You can install the Managed Switch on a flat surface or mount it in a standard 19-inch network equipment rack.



CAUTION

To prevent any damage or failure of the Managed Switch, please **DO NOT** block the ventilation holes.

Use the following guidelines when choosing a place to install the switch:

- Firm and steady flat surface.
- Proper power outlet location, not too far from the device.
- Visually inspect the power cord and see that it is secured to the AC power connector.
- Make sure that there is proper heat dissipation from and adequate ventilation around the switch. Do not place heavy objects on the Managed Switch.

Note:

The product appearance in the following diagrams might differ from the actual device as different equipment is used to showcase the installation examples.

2.3.1 Desktop Installation

The switch can be placed in any flat and steady surface with proper air ventilation. Four rubber feet with adhesive backing are provided for this kind of installation.

Procedures

- ① Attach rubber feet on the bottom at each corner of the device.
- ② Select a flat and steady surface to place the switch.
- ③ Allow adequate space for ventilation between the device and the objects around it.

2.3.2 Rack Installation

Either you can install an 8.5-inch switch or two 8.5-inch switches in a standard 19-inch network equipment rack. In the following sections, we will take a Managed Switch for example to separately demonstrate how to mount it or them in this size of rack space.



WARNING!

Please mount the Switch firmly in rack, otherwise it may fall and cause the system damage and possible injury to personnel.

2.3.2.1 Install a Managed Switch in a Rack

To install one set of the Managed Switch in a single rack space, you need the 19-inch rack-mount kit supplied with the switch. Just follow the procedures listed below for step-by-step instructions to install your switch in this rack space:

Step 1. Attach the supplied rack mounting brackets to the switch:

- 1.1. Attach the supplied regular mounting bracket to one side of the switch that you would like to install in the rack. (See Figure 2-1)
- 1.2. Attach the supplied long mounting bracket to the other side of the switch. (See Figure 2-1)

Step 2. Insert the screws provided in the rack-mount kit through each bracket and into the bracket mounting holes in the switch. (See Figure 2-1)

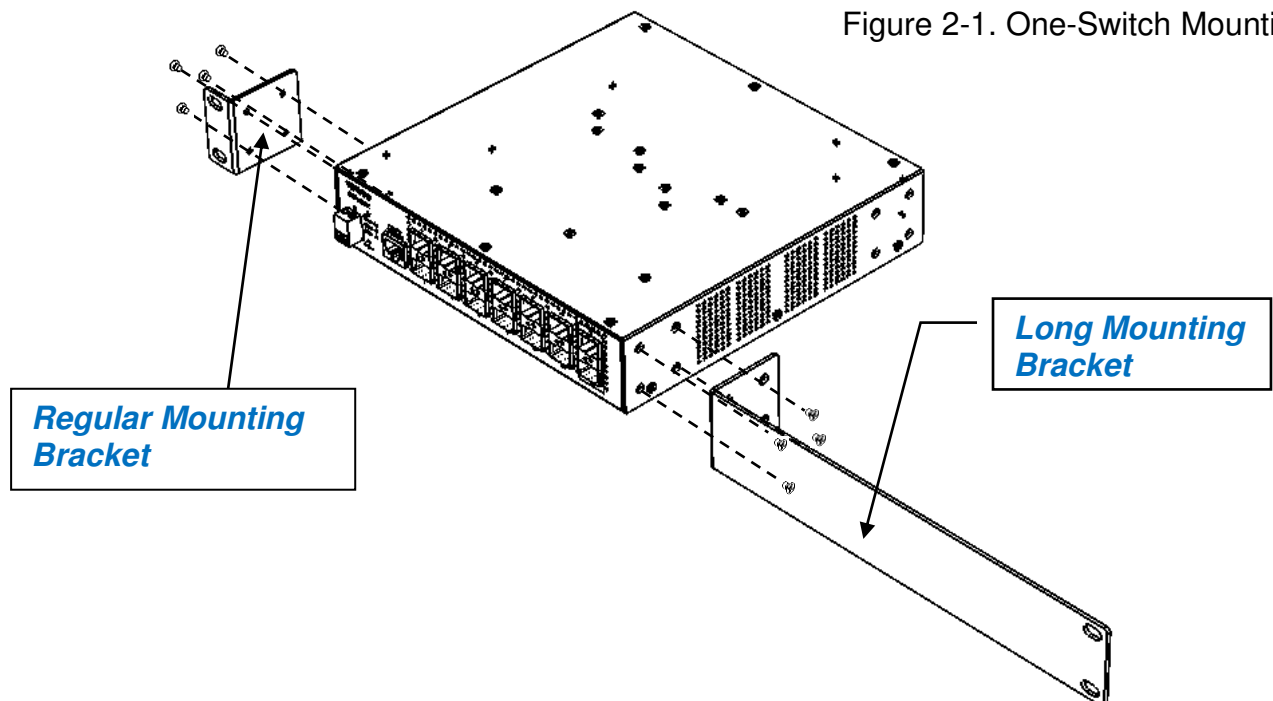

Step 3. Then, tighten the screws with the screwdriver to secure each bracket.

Step 4. Align the mounting holes in the brackets with the desired holes in the rack, and insert screws through each bracket and into the rack.

Step 5. Then, tighten the screws with the screwdriver to secure mounting brackets to the rack.

Step 6. Please ensure that the ventilation holes are not blocked.

2.3.2.2 Install Two Managed Switches in a Rack Using the Combine Kit

To install two sets of the 8.5-inch Managed Switch in a single rack space, you need the 19-inch rack-mount kit as well as the combine kit, supplied with the switch. Also follow the procedures listed below for step-by-step instructions to install your switches in this rack space:

Step 1. On the switch that will be mounted on the left side of the rack space, do the following:

- 1.1. Refer to Section 2.3.2.1 to attach the supplied regular mounting bracket to the left side of this switch.
- 1.2. Insert the screws provided in the rack-mount kit through the bracket and into the bracket mounting holes in the switches.
- 1.3. Tighten the screws with the screwdriver to secure the bracket.
- 1.4. On the right side of the switch, attach one L-shaped fixed piece by inserting the screws provided in the combine kit through this fixed piece and into the mounting holes in the switch. (See Figure 2-2)
- 1.5. Repeat the same manners as we had mentioned in Step 1.4 to install another L-shaped fixed piece on the same side of this switch. (See Figure 2-2)

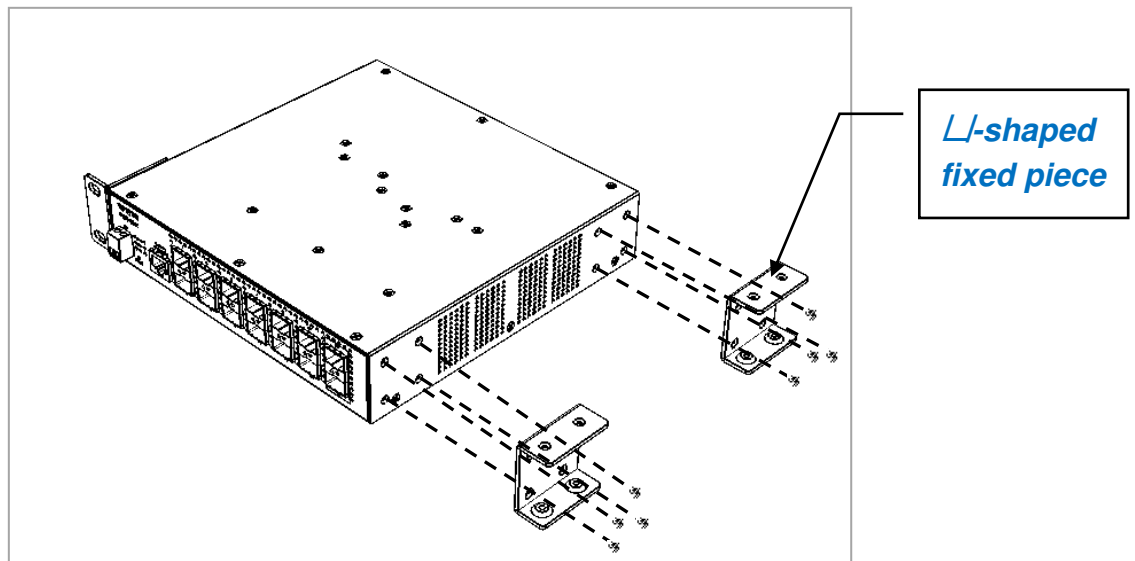

Figure 2-2. Install the L-shaped fixed pieces for two-switch mounting

- 1.6. Tighten the screws with the screwdriver to secure each middle mount to the right side of the switch.

Step 2. On the other switch that will be mounted on the right side of the rack space, do the following:

- 2.1. Also refer to Section 2.3.2.1 to attach the supplied regular mounting bracket to the right side of this switch.
- 2.2. Insert the screws provided in the rack-mount kit through the bracket and into the bracket mounting holes in the switches.
- 2.3. Tighten the screws with the screwdriver to secure the bracket.

2.4. On the left side of the switch, attach one L-shaped fixed piece in the reverse direction by inserting the screws provided in the combine kit through this fixed piece and into the mounting holes in the switch. (See Figure 2-3)

2.5. Repeat the same manners as we had mentioned in Step 2.4 to install another L-shaped fixed piece on the same side of the switch. (See Figure 2-3)

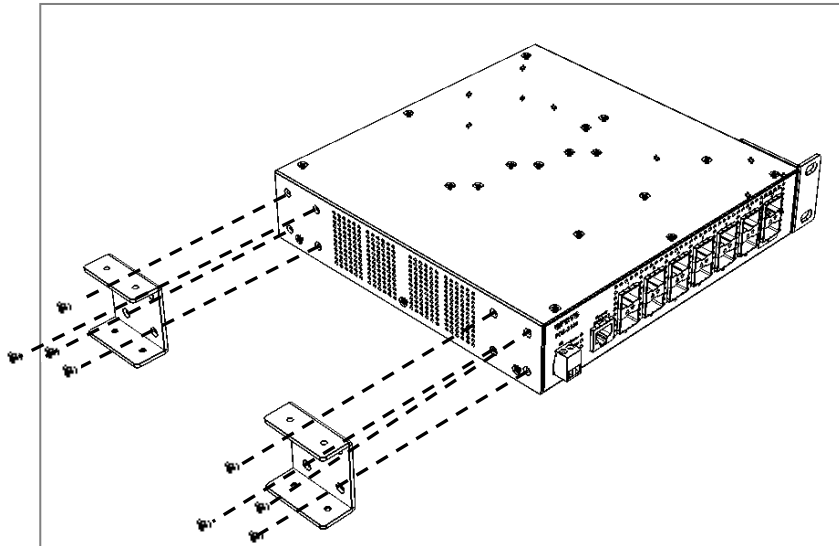

Figure 2-3. Install the L-shaped fixed pieces in the reverse direction for two-switch mounting

2.6. Tighten the screws with the screwdriver to secure each middle mount to the left side of the switch.

Step 3. Align the holes of the middle mount described in Step 1 on the left switch with the holes of the middle mount described in Step 2 on the right switch, and then lock them together carefully.

Step 4. Insert the screws provided in the combine kit through the holes into each middle mount. (See Figure 2-4)

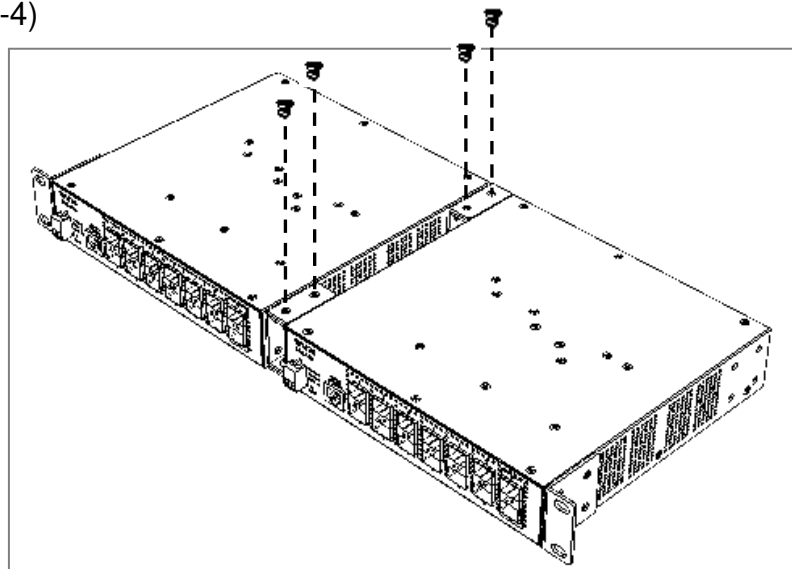

Figure 2-4. Screw the locked switches for two-switch mounting

Installation

Step 5. Tighten the screws with the screwdriver to secure each middle mount.

Step 6. Align the mounting holes in the regular brackets on both sides (the left side of the left switch and the right side of the right switch) with the desired holes in the rack, and insert the screws through each bracket and into the rack.

Step 7. Tighten the screws with the screwdriver to secure mounting brackets to the rack.

2.3.2.3 Install a Single/Two Managed Switches in a Rack Using 19-inch Rack-mount Bracket

Besides the mounting methods we previously mentioned, to install one or two sets of the Managed Switches in a single rack space; alternatively, you can use the 19-inch rack-mount bracket supplied with the switch. Also follow the procedures listed below for step-by-step instructions to install your switch/switches in this rack space:

Step 1. On the switch that will be mounted on the left side of the rack space, do the following:

- 1.1. Four bracket mounting holes for 19-inch rack-mount bracket are located at the bottom of each switch. (See Figure 2-5). Align these holes of this switch with the mounting holes on the most left side of the bracket you purchase.

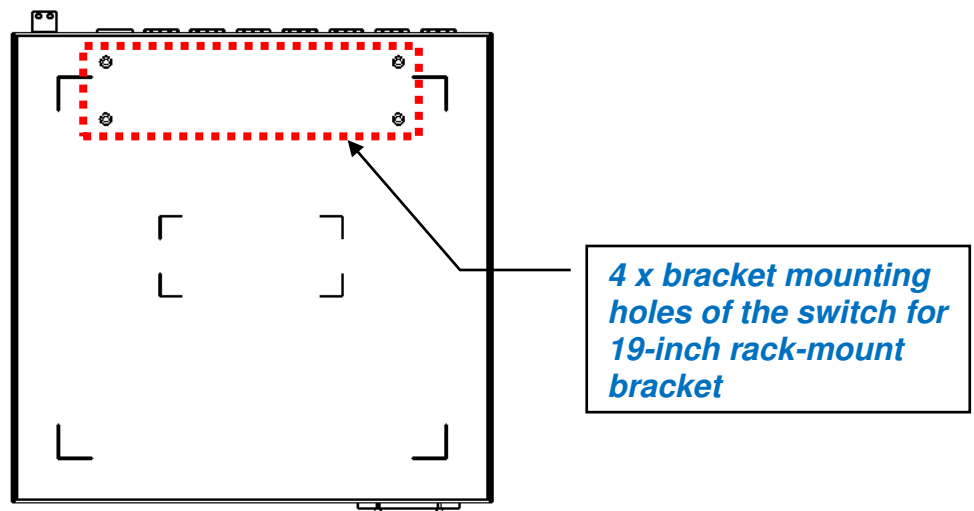

Figure 2-5. Bracket mounting holes located at the bottom of the switch

- 1.2. Insert the screws provided in the 19-inch rack-mount bracket through this bracket and into the bracket mounting holes at the bottom of the switch. (See Figure 2-6)
- 1.3. Tighten the screws with the screwdriver to secure this bracket.

Step 2. On the other switch that will be mounted on the right side of the rack space, do the following:

- 2.1. Also align four bracket mounting holes located at the bottom of this switch with the mounting holes on the most right side of the bracket you purchase.
- 2.2. Insert the screws provided in the 19-inch rack-mount bracket through this bracket and into these bracket mounting holes of the switch. (See Figure 2-6)
- 2.3. Tighten the screws with the screwdriver to secure this bracket.

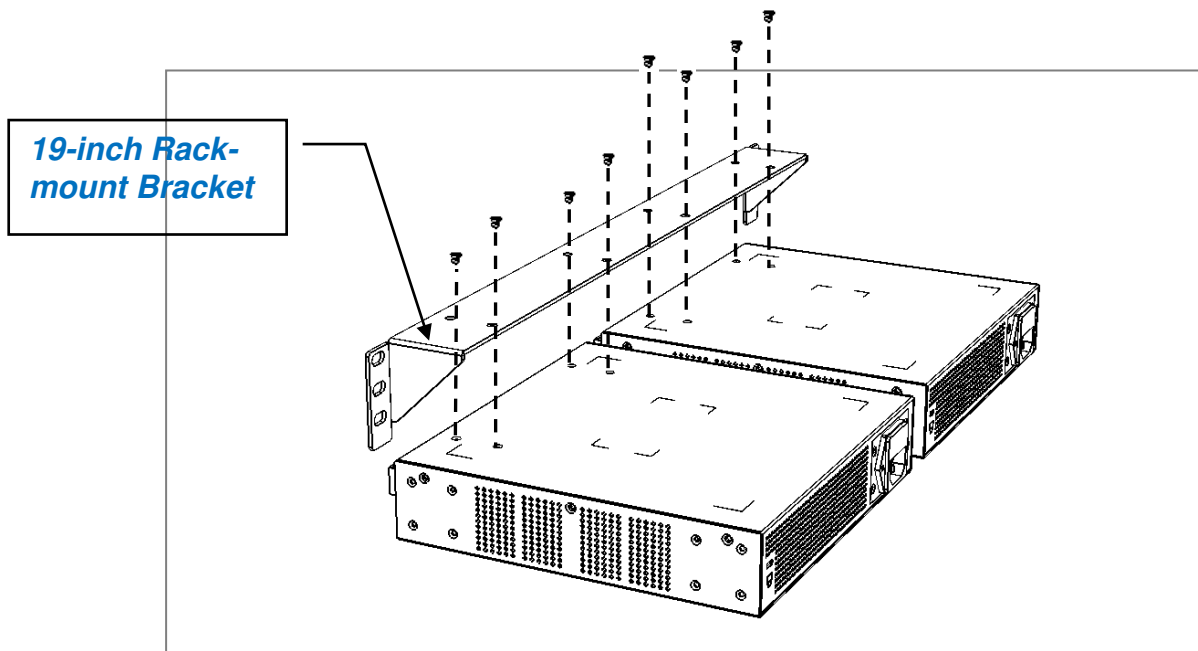

Figure 2-6. Install the 19-inch rack-mount bracket for two-switch mounting

- Step 3.** Align the mounting holes on both sides of this 19-inch rack-mount bracket with the desired holes in the rack, and insert the screws through this bracket and into the rack.
- Step 4.** Tighten the screws with the screwdriver to secure this bracket with the switch/switches to the rack.

2.4 Grounding the Managed Switch

Grounding helps to limit the effects of noise due to electromagnetic interference (EMI). Be sure to install the ground connection from the ground screw to the grounding surface before connecting devices.

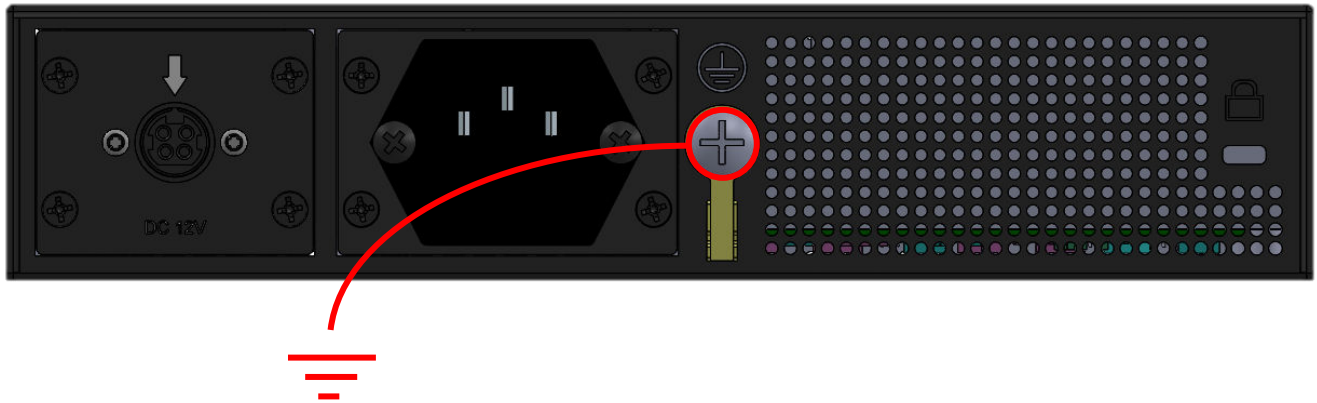

Figure 2-5 Grounding Wiring for the Managed Switch

2.5 Powering on the Managed Switch

The Managed Switch can be used with AC power supply 100-240VAC, 50–60 Hz, 0.4~0.2A, DC power supply 48VDC, 0.4A, or external DC power supply 12VDC, 0.33A (R7B adapter). After the Managed Switch is turned on, the Power LED indicators should light in green color. For more details about the power LED description, please refer to Section [1.4 LED Definitions](#).

Power Failure

In the event of power failure, unplug the power that is plugged into the switch. When power is resumed, plug the power back to the switch.

2.6 Connecting the Managed Switch to the Network

Connect to Network

The Managed Switch has 8 x 10/100/1000Base-T ports, 2 x 100M/1G/2.5G/5G/10GBase-T RJ-45 ports, and 2 x 1/10GBase-R SFP+ ports on the front panel. The TP ports can be plugged with UTP cable (Cat.5E for ports 1-8, Cat.5E/Cat.6/Cat.6A, 22~24 AWG, or better cabling for ports 9-10), whereas the uplink ports 11-12 can be plugged with 1000Base-X SFP Fiber transceiver or 10GBase-R SFP+ Fiber transceiver. The connection of the fiber port must be matched, i.e. Transmitter to Receiver, and vice versa.

2.7 Installing and Removing SFP/SFP+ Modules

2.7.1 Installing SFP/SFP+ Modules

To connect the fiber transceiver and LC/SC cable, use the following guidelines:

1. Position the SFP/SFP+ transceiver with the handle on top.
2. Locate the triangular marking in the slot and align it with the bottom of the transceiver.
3. Insert the SFP/SFP+ transceiver into the slot until it clicks into place.
4. Make sure the module is seated correctly before sliding the module into the slot. A click sounds when it is locked in place.

Note: If you are attaching fiber optic cables to the transceiver, continue with the following step. Otherwise, repeat the previous steps to install the remaining SFP/SFP+ transceivers in the device.

1. Remove the protective plug from the SFP/SFP+ transceiver.

Note: Do not remove the dust plug from the transceiver if you are not installing the fiber optic cable at this time. The dust plug protects hardware from dust contamination.

2. Insert the fiber cable into the transceiver. The connector snaps into place and locks.

3. Repeat the previous procedures to install any additional SFP/SFP+ transceivers in the switch. The fiber port is now set up.

2.7.2 Removing SFP/SFP+ Modules

To disconnect an LC/SC connector, use the following guidelines:

1. Press down and hold the locking clips on the upper side of the optic cable.
2. Pull the optic cable out to release it from the transceiver.
3. Hold the handle on the transceiver and pull the transceiver out of the slot.

2.8 Connecting the Switch to Console Port

The switch supports a secondary means of management. By connecting the RJ-45 to RS232 serial cable between a COM port on your PC (9-pin D-sub female) and the switch's console port, a wired connection for management can be established.



Operation

A built-in management module of Managed Switch provides users flexible interfaces to configure, control and monitor the system remotely and locally. To know the further information about the operation of Managed Switch, please refer to Network Management User's Manual for the detailed management functions and required installation and operation procedures.

3.1 Network Management

The following is a list of management options available in this Managed Switch:

- Local Console Management
- Telnet Management
- SNMP Management
- Web Management

Local Console Management

Users may connect a Terminal or PC running the Terminal Emulation program (such as Putty or Tera Term) with the following serial console port settings, to the Managed Switch console port directly via RS-232 cable to configure, control and monitor the system. This is often referred to as Out-Of-Band management.

Baud rate:	9600
Data bits:	8
Parity:	none
Stop bits:	1
Flow control:	none

Console management is useful when there is no network connection to the Switch, for instance configuring the Managed Switch for the first time.

Telnet Management

Telnet is done through the network. Once there is a network connection to the Managed Switch, users can use Telnet to configure, control and monitor the system. Using the network connection to manage is often referred to as In-Band-Management.

SNMP Management

SNMP is also In-Band-Management and requires a network connection to the Managed Switch. The Managed Switch private Management Information Bases (MIB) is provided for SNMP-based network management program to configure, control and monitor the system.

Web Management

Web Management is done over the network. Once the Managed Switch is available on the network, you can login and monitor the status of it through a web browser remotely or locally. Web management in the local site, especially for the first time use of the Managed Switch to set up the needed IP, can also be done through one of the SFP/SFP+ ports located on the front panel of the Managed Switch. A converter and direct RJ-45 LAN cable connection between a PC and the Managed Switch are required for this management.

4

Maintenance

This Managed Switch is easy to maintain. The procedures are suggested when you would like to identify faults, perform hardware replacement and firmware upgrade.

4.1 Fault Identification

Identifying faults can greatly reduce the times required to find problem and solution. Users may perform local check or remote check to find the problems.

4.1.1 Local Check

Users can perform local check by observing LED indicators status or check system setup and configuration through console connection.

- When the whole system fails to function,
 1. Check Power LED status
 2. Check Power connection
 3. Reset power

- When certain network link fails to function,
 1. Locate the port of the switch
 2. Check LINK/ACT/Speed LED of the port
 3. Check Status LED of the port
 4. Check cable connection between the port and the connected device
 5. Reset power

- When local Console fails to function,
 1. Check COM LED status
 2. Check Console port connection
 3. Check Console configuration
 4. Reset power

4.1.2 Remote Check

Users may check the Managed Switch through SNMP manager remotely. For detailed procedures, please refer to the Network Management User's Manual.

4.2 Hardware Replacement Procedures



WARNING!

The Managed Switch contains no user-serviceable parts. DO NOT, UNDER ANY CIRCUMSTANCES, open and attempt to repair it.

Failure to observe this warning could result in personal injury or death from electrical shock.

Failure to observe the above warning will immediately void any Warranty.

4.3 Firmware Upgrade

This Managed Switch may perform the firmware upgrade when required. The latest firmware can be obtained from your sales representative. For the detailed upgrade procedures, please refer to Network Management User's Manual.



CONNECTION TECHNOLOGY SYSTEMS

18F-6, No.79, Sec.1, Xintai 5th Rd.,

XiZhi Dist., New Taipei City 221, Taiwan(R.O.C)

Tel: +886-2-2698-9661

Fax: +886-2-2698-9662

Dir.Line:+886-2-2698-9201

www.ctsystem.com