



CONNECTION TECHNOLOGY SYSTEMS

**IES-3110
Managed Industrial Gigabit
Ethernet Switch**

User's Guide

Version 0.90

Trademarks

Contents are subject to revision without prior notice.
All other trademarks remain the property of their respective owners.

Copyright Statement

This publication may not be reproduced as a whole or in part, in any way whatsoever unless prior consent has been obtained.

FCC Warning

This equipment has been tested and found to comply with the limits for a Class-A digital device, pursuant to Part 15 of the FCC Rules. These limitations are designed to provide reasonable protection against harmful interference in a residential installation. This equipment generates, uses and can radiate radio frequency energy and, if the equipment is not installed and used in accordance with the instructions, it may cause harmful interference to radio communications. However, there is no guarantee that interference will not occur in a particular installation. If this equipment does cause harmful interference to radio or television reception, which can be determined by turning the equipment off and on, the user is encouraged to try to correct the interference by one or more of the following measures:

- Reorient or relocate the receiving antenna.
- Increase the separation between the equipment and receiver.
- Connect the equipment into an outlet on a circuit different from that to which the receiver is connected.
- Consult your local distributors or an experienced radio/TV technician for help.
- Shielded interface cables must be used in order to comply with emission limits.

Changes or modifications to the equipment, which are not approved by the party responsible for compliance, could affect the user's authority to operate the equipment.

Copyright © 2017 All Rights Reserved.

Company has an on-going policy of upgrading its products and it may be possible that information in this document is not up-to-date. Please check with your local distributors for the latest information. No part of this document can be copied or reproduced in any form without written consent from the company.

Trademarks:

All trade names and trademarks are the properties of their respective companies.

Revision History

Version	Date	Description
0.90	20161007	First release
0.90	20170109	Remove Bluetooth

Table of Contents

1. OVERVIEW.....	5
1.1 Specification	5
1.2 Panel Layout	7
2. INSTALLATION	9
2.1 Installation Requirements	9
2.2 Checking the Package Contents	9
2.3 Installing the Managed Industrial Gigabit Ethernet Switch.....	10
2.4 Powering the Managed Industrial Gigabit Ethernet Switch.....	12
2.5 Connecting the switch to Network	14
3. OPERATION	14
3.1 LED Definitions.....	15
4. MAINTENANCE	16
4.1 Fault Identification	16
4.2 Hardware Replacement Procedures	16
4.3 Firmware and Configuration Upgrade	17

1. OVERVIEW

Thank you for choosing the Managed Industrial Gigabit Ethernet Switches. The Managed Industrial Gigabit Ethernet Switches are designed to meet the massive needs for Gigabit Ethernet network deployments and aim at Industrial applications that demand wide range of operating temperature. They are fully compliant with IEEE802.3, 802.3u, 802.3ab, 802.3z, 802.1p, 802.1q and 802.3x standards. The built-in management module allows users to configure this Managed Industrial Gigabit Ethernet Switch and monitor the operation status locally or remotely through network.

With power redundancy, users can prevent network disconnection from unexpected power outage. By employing store and forward switching mechanism, the Switch provides low latency and faster data transmission. Moreover, it also supports more advanced-ethernet management functions, such as QoS and VLAN. Users can configure the required settings of the Switch and monitor its real-time operational status via Command Line Interface (CLI) and Web GUI.

1.1 Specification

Interface

8 x 10/100/1000Mbps RJ-45 ports

2 x Combo ports (10/100/1000Mbps RJ-45 + 100/1000Mbps SFP)

USB : 1 x USB 2.0 (Host Type A)

Console : 1 x RS-232 (RJ-45)

Standards

IEEE802.3 10Base-T

IEEE802.3u 100Base-TX/FX

IEEE802.3ab 1000Base-T

IEEE802.3az EEE

IEEE802.3z 1000Base-X

IEEE802.1p Priority

IEEE802.1q Tag VLAN

IEEE802.3x Flow Control

IEEE802.1D/IEEE802.1w STP/RSTP

H/W Specification

Store and Forward Switching Mechanism
Auto Crossover for MDI/MDI-X in TP Port
Auto Negotiation in TP Port
Half/Full Duplex Mode Operation
Jumbo Frame up to : 9K Bytes
MAC Address Table : 16K
Non-Blocking Switching Fabric : 20Gbps
VLAN ID : 4K
1 Digital Output(Alarm Relay)

Switch Features

IEEE802.1q Tag Based VLAN
IGMP Snooping v1/v2
QoS Based on P-bit, VLAN
Broadcast Storm Control
Port Mirroring
Port Trunking
Loop Detection

Management

Telnet CLI
SNMP v1/v2c
DHCP Client
FTP/HTTP/TFTP/USB Firmware Upgrade
Dual Image
SNTP
SSHv2
Eventlog
Syslog

Cable Specifications

The following table contains various cable specifications for the Managed Switch. Please make sure to use the proper cable when connecting the Managed Industrial Gigabit Ethernet Switches.

Cable Type	Description
10BASE-T	UTP Category 3, 4, 5 (100 meters max.) EIA/TIA- 568 150-ohm STP (100 meters max.)
100BASE-TX	UTP Cat. 5 (100 meters max.) EIA/TIA-568 150-ohm STP (100 meters max.)
1000BASE-T	UTP Cat. 5e (100 meters max.) UTP Cat. 5 (100 meters max.) EIA/TIA-568B 150-ohm STP (100 meters max.)
100BASE-FX	Multi-mode fiber module(2km) / Single-mode fiber module
1000BASE-SX	Multi-mode fiber module (550m)
1000BASE-LX	Single-mode fiber module (10km)
1000BASE-LH	Single-mode fiber module (30km/50km)
1000BASE-ZX	Single-mode fiber module (80km)
Mini-GBIC	SFP Transceiver for: 1000BASE-SX Multi-mode fiber module (550m) 1000BASE-LX Single-mode fiber module (10km) 1000BASE-LH Single-mode fiber module (30km/50km) 1000BASE-ZX Single-mode fiber module (80km)

1.2 Panel Layout

Front Panel

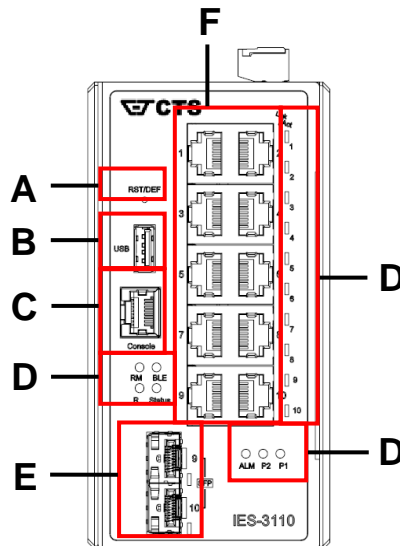

Figure 1. Front Panel

A. Reset Button:

- Insert a pin or paper clip to press the Reset Button for 5 seconds to restart the system.
- Insert a pin or paper clip to press the Reset Button for 10 seconds to reset the device back to defaults.

- B. USB host (for more information, please refer to [chapter 4.3](#))
- C. Console port (RJ-45 to RS-232)
- D. LEDs (for more information, please refer to [chapter 3.1](#))
- E. 100/1000Mbps SFP port(s)
- F. 10/100/1000Mbps RJ-45 port(s)

Rear Panel

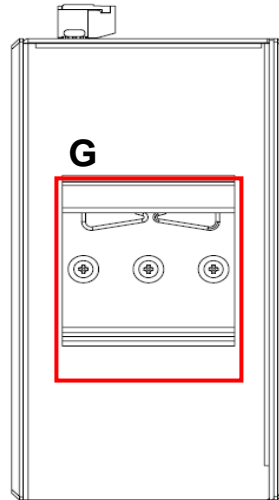

Figure 4. Rear Panel

- G. Din-Rail metal spring (for more information, please refer to [chapter 2.3](#))

Top Panel

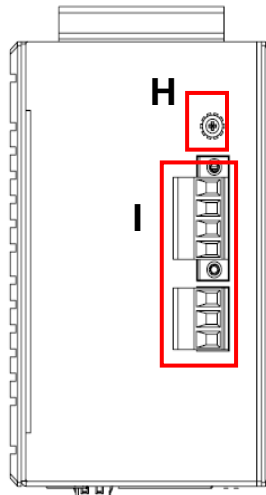

Figure 5. Top Panel

- H. Ground screw (for more information, please refer to [chapter 2.3](#))
- I. Terminal blocks (for more information, please refer to [chapter 2.4](#))

2. INSTALLATION

To properly install the Managed Industrial Gigabit Ethernet Switch, please follow the procedures listed below. Procedures covered in this chapter are described below in separate sections.

- Installation Requirements
- Unpacking the Managed Industrial Gigabit Ethernet Switch
- Installing the Managed Industrial Gigabit Ethernet Switch
- Powering on the Managed Industrial Gigabit Ethernet Switch
- Connecting the Managed Industrial Gigabit Ethernet Switch to the Network

2.1 Installation Requirements



ATTENTION

Be sure to power off before installing or wiring your Managed Industrial Gigabit Ethernet Switch.

Be sure to calculate the maximum possible current in each power wire and common wire. If the current goes above the maximum ratings, the wiring could overheat, causing serious damage to your equipment.

Be sure to read and follow important guidelines as below:

- Do not run signal or communications wiring and power wiring through the same wire conduit. Wires with different signal characteristics should be routed separately to avoid interference.
- It is recommended that wiring which shares similar electrical characteristics can be bundled together.
- Keep input wiring and output wiring separate and label the wiring to all devices in the system if necessary.

2.2 Checking the Package Contents

Unpack the package carefully and check the package contents. The standard package should contain the following items:

- 1 Managed Industrial Gigabit Ethernet Switch
- 1 Documentation CD

Note: If any of the above items is found missing or damaged, please contact your local sales representative for support or replacement.

2.3 Installing the Managed Industrial Gigabit Ethernet Switch



ATTENTION

This product is intended to be mounted to a well-grounded mounting surface, such as a metal panel.

DIN-Rail

STEP 1 : Insert the top of the DIN-Rail into the slot just below the metal spring

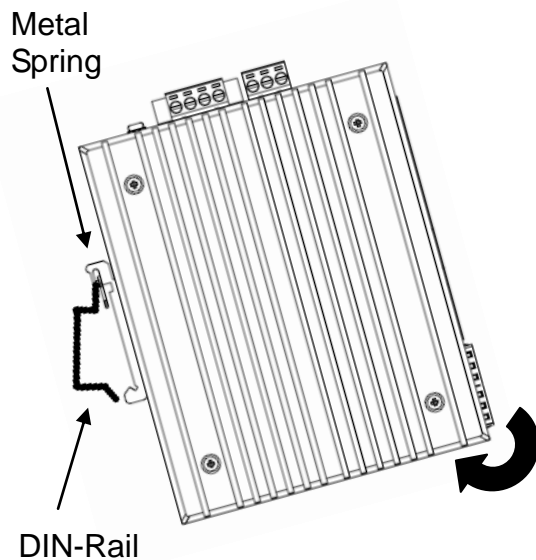

STEP 2 : The DIN-Rail attachment unit will be snapped into place as shown

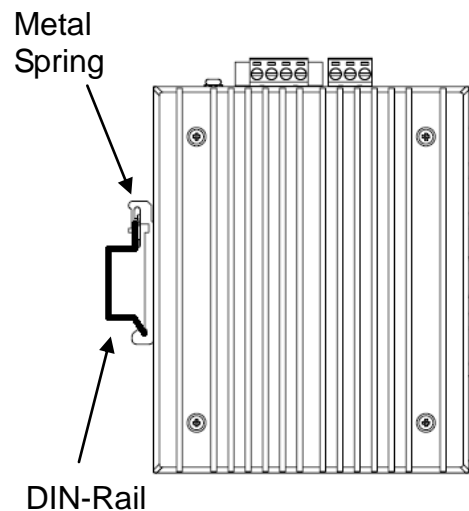

Wall Mount (Optional)

Use a wall mount with two screws to install the Managed Industrial Gigabit Ethernet Switch on the wall by a screwdriver. The Managed Industrial Gigabit Ethernet Switch is able to be installed in either vertical or horizontal direction for users need by a wall mount. The examples are shown in Figure 6 and 7.

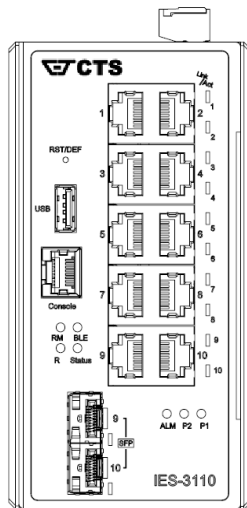

Figure 6. Install the Managed Industrial Gigabit Ethernet Switch in vertical direction.

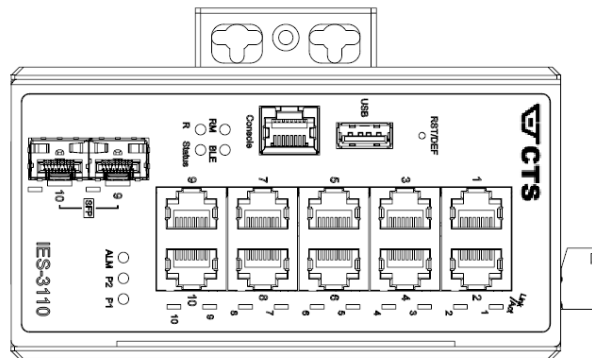

Figure 7. Install the Managed Industrial Gigabit Ethernet Switch in horizontal direction

Grounding the Managed Industrial Gigabit Ethernet Switch

Grounding helps to limit the effects of noise due to electromagnetic interference (EMI). Be sure to install the ground connection from the ground screw to the grounding surface before connecting devices.

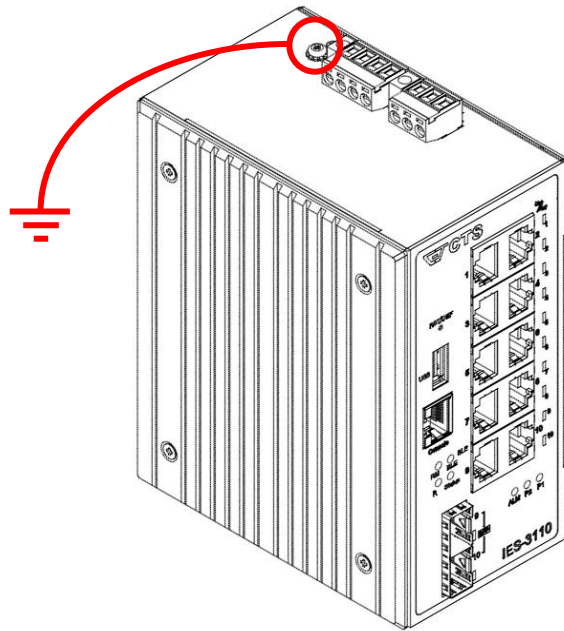

Figure 8. Grounding wiring

2.4 Powering the Managed Industrial Gigabit Ethernet Switch

The Managed Industrial Gigabit Ethernet Switch can be used with DC power 48-54 VDC with the terminal block. The terminal block is located on the upper panel of the Managed Industrial Gigabit Ethernet Switch. Before powering the Managed Industrial Gigabit Ethernet Switch, please make sure that network cables and power cables are securely connected.



ATTENTION

Before connecting the Managed Industrial Gigabit Ethernet Switch to the DC power inputs, make sure the DC power source voltage is stable.

Wiring the terminal blocks

P1 and P2 power supply are two pairs of contacts on the terminal block for power redundancy purpose. The redundant power supply will take over seamlessly when one power source is down to protect your device or network from the loss of power.

Power Input Configuration

Insert the positive and negative wires into the “+” and “-” contacts on the terminal block.

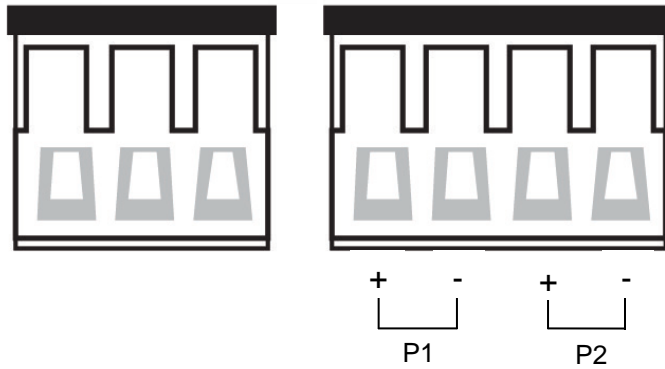

Tighten the wire-clamping screws to fix DC wires by using a flat-head screwdriver.

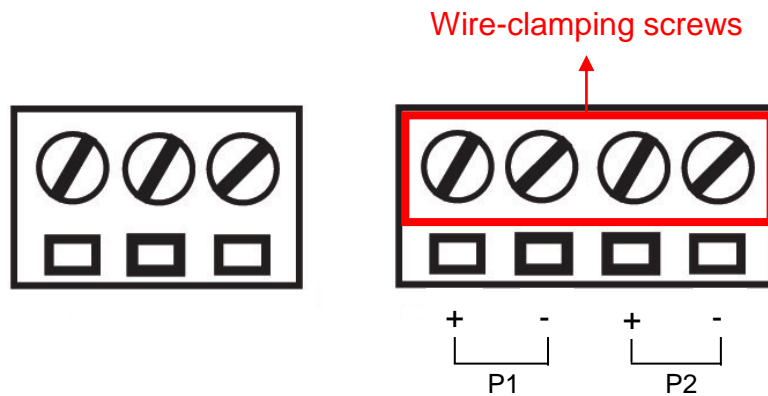

Relay Alarm Output Configuration

Relay alarm has 3 contacts on the terminal block used to connect alarm devices such as speakers or LEDs to alert users when the redundant power or a port link is disconnected. The right contact is normal closed, the left contact is normal open, and the middle contact is com shared by normal open and normal closed.

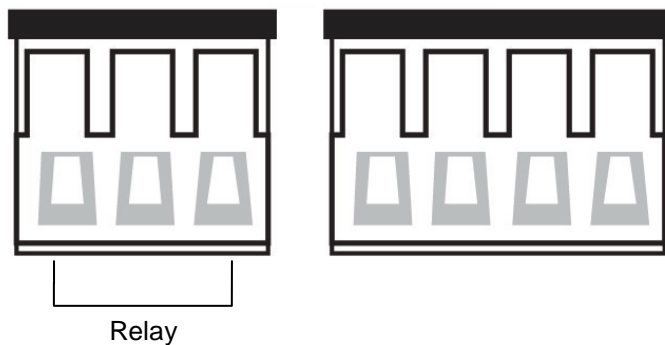

Tighten the wire-clamping screws to fix alarm-device wires by using a flat-head screwdriver.



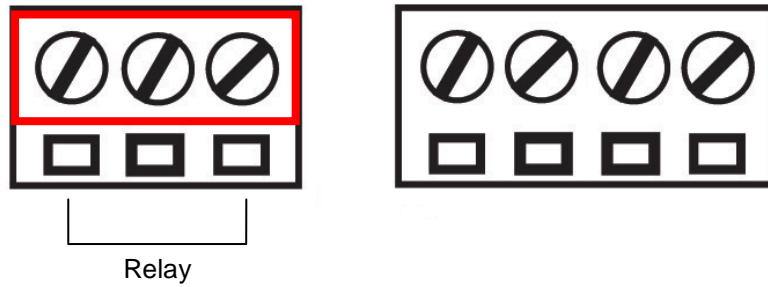

Note: If there is no power redundancy, the relay alarm is not available.

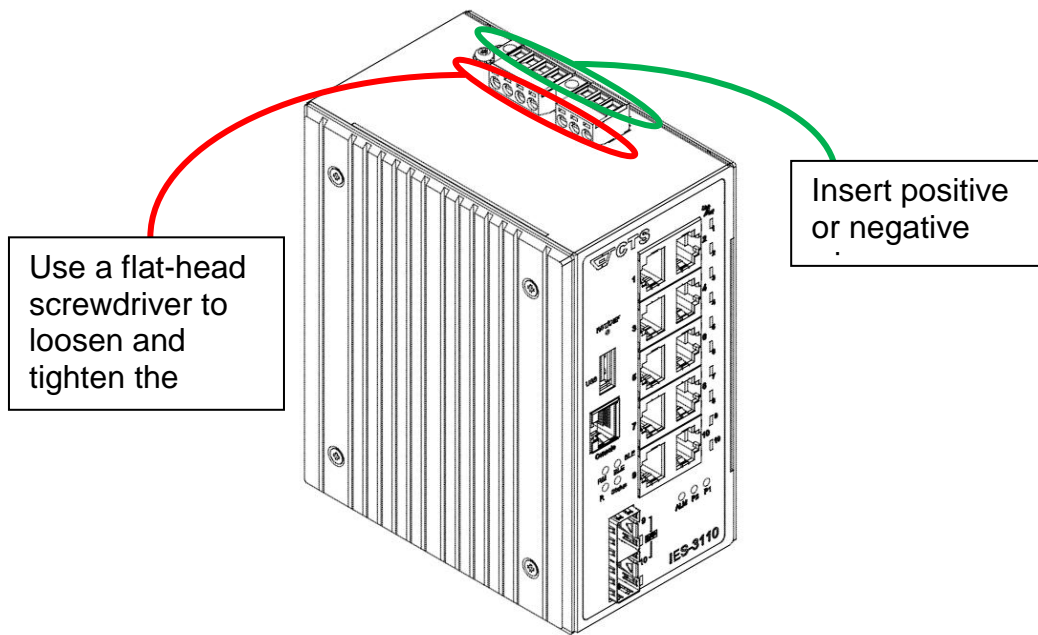

Figure 9. Illustration of wiring the terminal blocks

2.5 Connecting the switch to Network

Connect to Network

This Managed Industrial Gigabit Ethernet Switch has 2 uplink ports (RJ-45 or SFP) and 8 downlink 10/100/1000Mbps RJ-45 ports for you to implement it in your Industrial environment. All RJ-45 ports can be inserted by 10/100/1000Base-T cables, connecting to the end devices. The fiber port(s) can accept any kind of connector with proper SFP transceiver (mini-GBIC).

3. OPERATION

The Managed Industrial Gigabit Ethernet Switch is Plug & Play. Real-time operational status can be monitored through a set of LED indicators located on the front panel. A built-in management module provides users with flexible interfaces to configure, control and monitor the complete system remotely.

3.1 LED Definitions

LED	Definition	Color	Operation
P1	Power	Off	Device is powered down.
		Green	Device is powered on.
P2	Power	Off	Device is powered down.
		Green	Device is powered on.
STATUS	System Status	Orange	System is booting up.
		Green	System is working normally.
		Green Blinking	When a USB is inserted, the Status LED indicator will blink 3 times in green.
			When upgrade procedure is completed, the Status LED indicator will blink 3 times in green.
		Orange Blinking	When the system is set back to default factory setting, the Status LED indicator will blink 3 times in orange.
			When the system is restarted, the Status LED indicator will blink once in orange.
System is undergoing upgrading procedure.			
ALM	Alarm	Off	Power supplies link up.
		Orange	One of power supplies links down.
RM	Role	Off	The role of switch is slave.
		Green	The role of switch is master.
R	Function	Off	Ring Detection is disabled.
		Green	Ring Detection is enabled.
		Orange Blinking	Local Port is link down in a Ring topology.
		Green Blinking	Remote Port is link down in a Ring topology.
LINK/ACT 1~10	Port Status	Off	Port link is down
		Orange	Link is up and works at 10/100Mbps.
		Orange Blinking	Receiving and transmitting data.
		Green	Link is up and works at 1000Mbps.
		Green Blinking	Receiving and transmitting data.

4. MAINTENANCE

It is easy to use and maintain this Managed Industrial Gigabit Ethernet Switch. The procedures are suggested when you want to identify faults, perform hardware replacement and firmware upgrading.

4.1 Fault Identification

Identifying faults can greatly reduce the time required to find the problem and solution. Users may perform local or remote checks to find the problems.

Local Check

Users can perform local checks by observing LED indicators status.

- When the whole system fails to function,
 - Check Power LED status
 - Check Power connection
 - Reset power

- When certain network link fails to function,
 - Locate the port of the switch
 - Check Port Link Status LED
 - Check cable connection between the port and the connected device
 - Reset power

Remote Check

Users may check the Managed Industrial Gigabit Ethernet Switch through SNMP manager remotely. For detailed procedures, please refer to the Network Management User's Manual.

4.2 Hardware Replacement Procedures



ATTENTION

The Managed Industrial Gigabit Ethernet Switch contains no user-serviceable parts. DO NOT, UNDER ANY CIRCUMSTANCES, open and attempt to repair it.

Failure to observe this warning could result in personal injury or death from electrical shock.

Failure to observe the above warning will immediately void

any Warranty.

4.3 Firmware and Configuration Upgrade

This Managed Industrial Gigabit Ethernet Switch may perform firmware and configuration upgrading when required. New firmware can be obtained from your sales representative. For detailed upgrading procedures, please refer to the Network Management User's Manual.

Automatic Firmware and Configuration Upgrade via USB host

The Managed Industrial Gigabit Ethernet Switch's firmware and configuration can also be upgraded automatically via USB host.

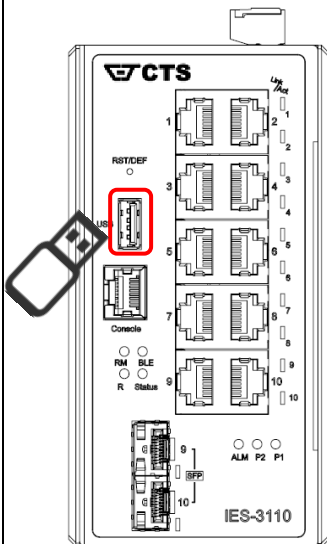

- Allows the network administrator for provisioning a device by just powering on and inserting disk
- Automatically upgrade firmware and/or configuration when plug in an USB flash disk or hard disk

USB support

- Flash disk or hard disk (USB mass storage) with partition (Logic unit number, LUN)
- File system : FAT12, FAT16, FAT32, NTFS3.1(read-only) and before

Automatic Firmware and Configuration Upgrade Process



Preparation steps before inserting the USB disk

- Rename the firmware name as:
cts-fw-<model_name>.<admin_user>.<password>
- Rename the configuration file name as:
cts-cfg-<model_name>.<admin_user>.<password>

